

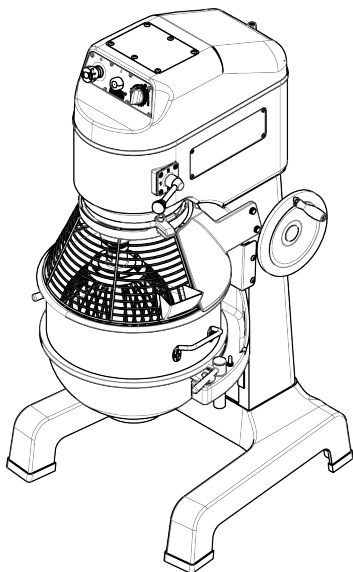

OPTIONAL ACCESSORIES

- 20L Reduction Kit w/tools Ref # ACC20/SP40
- Reinforced Whisk (stainless steel) Ref # 40031-A
- Bowl Scraper Ref # SP40/SCRP



STANDARDS



PRODUCT FEATURES

- 1.5 HP Induction motor
- Belt driven permanently lubricated transmission
- Heat-treated hardened steel alloy gears and shafts
- Three fixed speeds
- Thermal overload protection
- Rigid cast iron body
- 40 litre stainless steel bowl
- Removable stainless steel bowl safety guard with built in ingredient chute
- Safety interlocked bowl guard and bowl lift
- Front mounted controls
- 15 minute analogue timer
- Non-slip rubber feet
- 1.8m cord no plug supplied

STANDARD ACCESSORIES

- 40 litre bowl (stainless steel) Ref # SP40-32
- Beater (aluminum) Ref # SP40-30
- Whisk (stainless steel) Ref # SP40-31
- Dough hook (aluminum) Ref # SP40-29
- Bowl Trolley with handle Ref # Trolley/40-N

TECHNICAL DATA

Power	1300W	2.0 HP
Electrical data	240V/50/1	Draw 9.85 Amps
	No plug supplied	
Speed	3 speed - 99 / 167 / 329 rpm	
Dimensions (LxWxH)	738 x 638 x 1316 mm	
Gross weight	284 kg	
Reference	SP40-S	

